

CP36U How to use Adjusting Switch Unit (ASW-Unit)

Output of CP-36U can be adjusted by using "Adjusting Switch Unit (ASW-Unit).

This document explains how to use the ASW-Unit.

◆ What is ASW-unit

MIDORI's Contactless Angle Sensor "CP36U" can be reset and adjust output characteristics by using ASW-Unit after our shipment. ASW-Unit is the setting device for this setting operation.

The following variations of CP36U are available as products that can use the ASW-Unit.

[Fixed Cable type]--- The ASW-Unit has installed on the fixed wiring cable of the sensor.

One ASW-Unit is attached to each sensor. The output can be set immediately at the place without having to carry the ASW-Unit separately.

[Detachable Cable type]--- The ASW-Unit is removable from the wiring cable of the sensor. Only when you want to set the output, it can be attached to the sensor for setting. It can be shared to use with multiple CP36U.

After setting, you can remove the ASW-Unit and connect cable connector, the sensor works as normal.

* Detachable Cable type is not attached to ASW-Unit at first. The ASW-Unit is available to be purchased separately.

◆ The shape of ASW-Unit

[Appearance]



[Dimension] ASW-Unit for Detachable Cable type

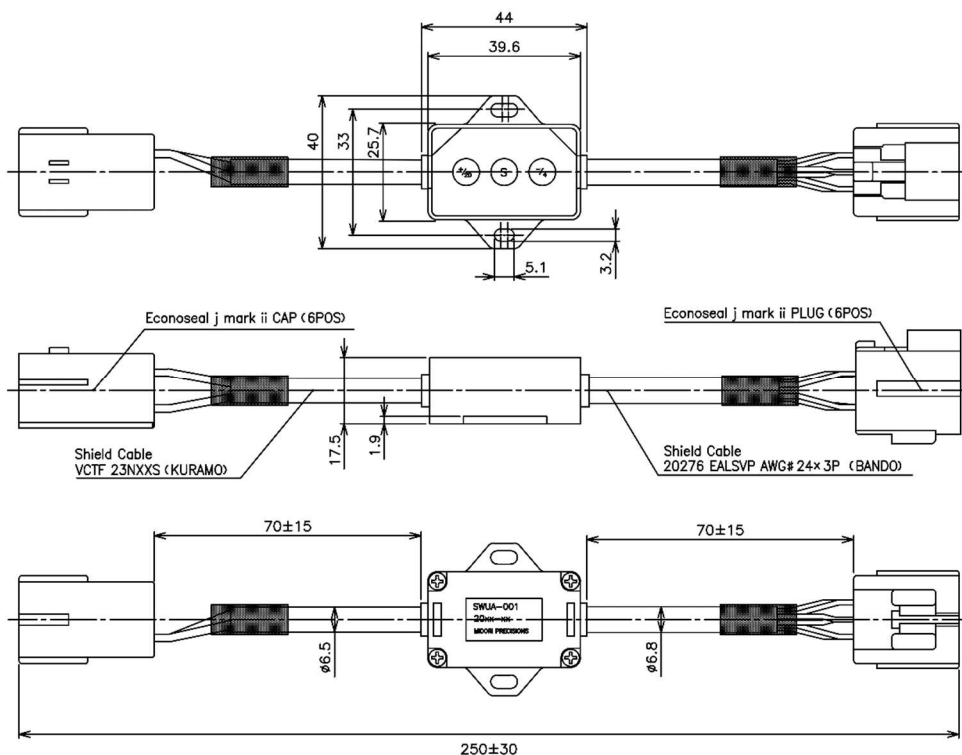

◆ What ASW-Unit can do

The following settings can be made by operating the buttons on the ASW-Unit.

1) Teach-in Electrical Angle Range

By using the "Elective angle range setting" function, any position of the shaft can be set output 4mA and 20mA .

(Please refer to the right figure.)

* Adjustable angle range : $1^{\circ} \sim 360^{\circ}$

If FS is set less than 1° or more than 359° , FS will be automatically reset to 360° .

* The accuracy assurance range : FS= $18^{\circ} \sim 360^{\circ}$

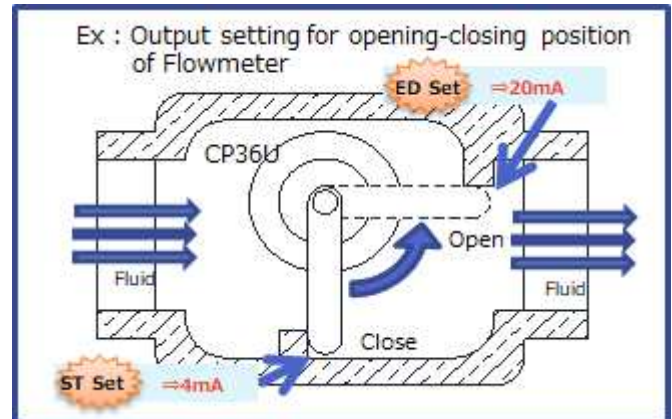

2) Zero/Span Adjustment

By using the "ZERO adjustment" function, the output at the position of 4mA can be finely adjusted within the range of 3~5mA.

By using the "SPAN adjustment" function, the output at the position of 4mA can be finely adjusted within the range of 19~21mA.

In each function, the adjustment resolution is $4.55\mu\text{A}$ (theoretical).

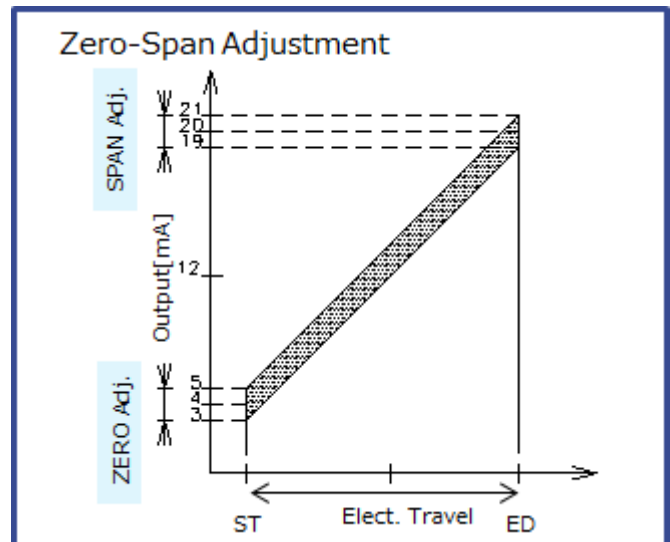

3) Output increase direction Setting

By using the "CW setting" function, the output Increasing direction can be set to CW increasing.

By using the "CCW setting" function, the output Increasing direction can be set to CCW increasing.

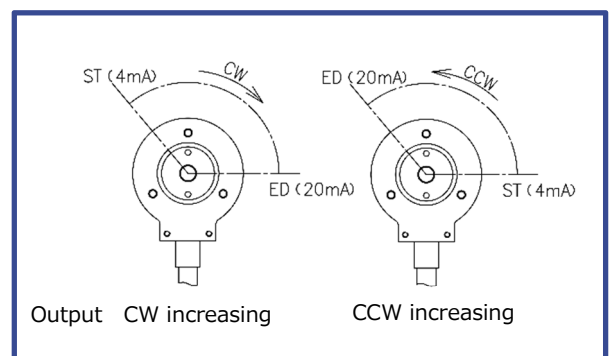

4) Reset

By using the "Reset setting" function, CP36U is returned to the prior setting or initialized to factory setting.

◆ Operating instruction of ASW-Unit

~Preparation~

- (1) Connect the ASW-Unit between the connectors of the cables if it is Detachable Cable type.
 - (2) Fixed Cable type is used as it is.
 - (3) Apply DC24±8V to CP36U.
 - (4) If you need to check the sensor output state, please prepare an instrument by yourself.
 - (5) Remove the Protection Cover and set according to the function you would like to use.
- The operation procedure is mentioned from the next page.

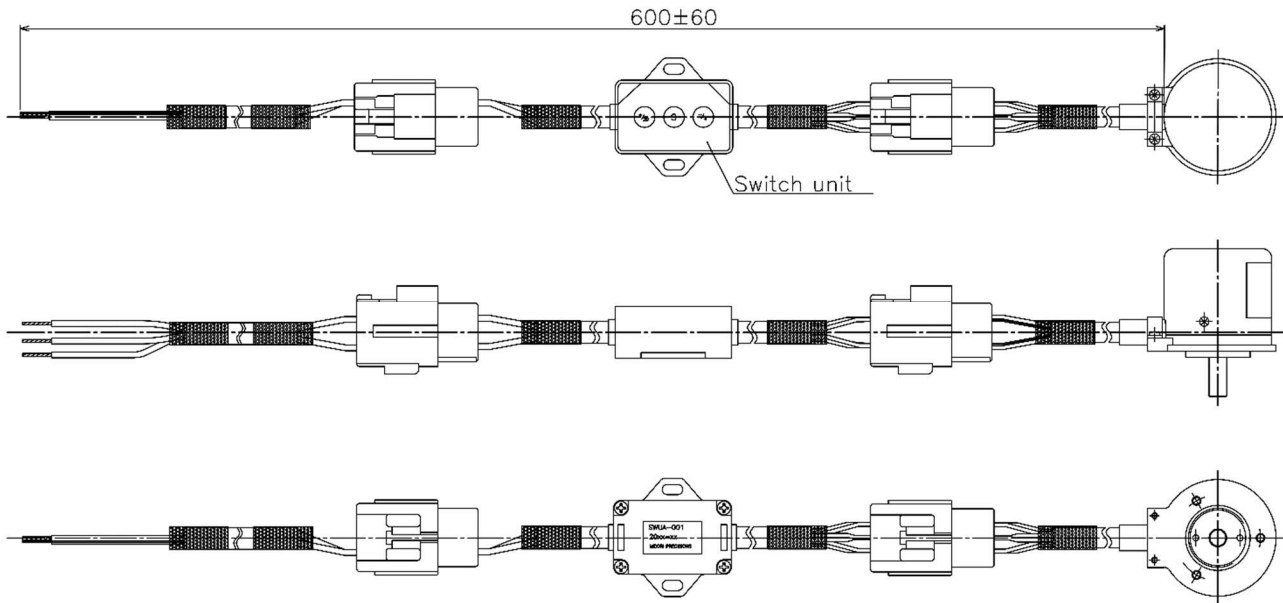

Detachable Cable type, all connected

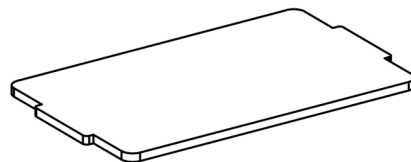

Protection Cover

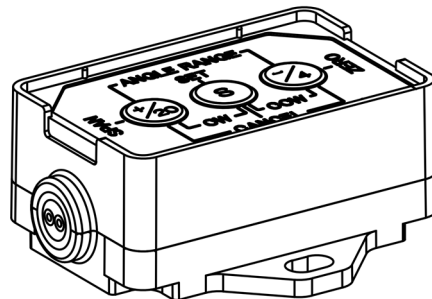

ASW-Unit

*Depending on the direction of the Protection Cover,
it may be difficult to put in the ASW-Unit.

~Operation Buttons~

This ASW-Unit has the following 3 buttons.

- (1) [+/20] Button
- (2) [S] Button
- (3) [-/4] Button

Refer to the picture on the right for the button layout.

Please press the button firmly until you feel a click.

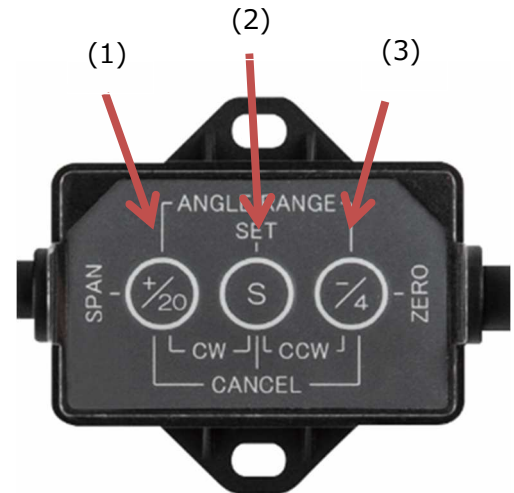

~Operation Procedure~

1) Elective angle range setting function

To set the effective angle range.

(1) Start setting

- Press and hold [+/20] and [-/4] buttons for 3 seconds or more.



(2) Set any angle position to output 4mA and 20mA

- Press the [-/4] button at the shaft position of CP36U where you would like to be 4mA. When the button is pressed, output of CP36U will be 4mA.
- Press the [+/20] button at the shaft position of CP36U where you would like to be 20mA. When the button is pressed, output of CP36U will be 20mA

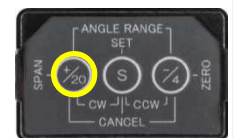

(3) Fix (Save) a setting

- Press and hold [S] button for 3 seconds or more.



(4) Stop setting procedure halfway

- Press and hold all [+/20], [S] & [-/4] buttons for 3 seconds or more.

If the button is not pressed for more than 5 minutes during setting operation, the operation will be ended.

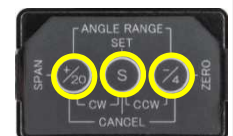

2) ZERO SPAN adjustment function

2)-1 To fine-tune the output around 4mA

(1) Start ZERO adjustment

- Press and hold [-/4] button for 3 seconds or more.

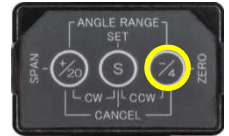

(2) Decrease output current at 4mA

- Press [-/4] button ----- Output will be decreased gradually by pressing the button. Output will be changed continuously if press and hold the button.

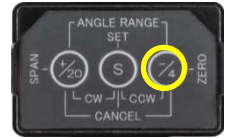

(3) Increase output current at 4mA

- Press [+20] button ----- Output will be decreased gradually by pressing the button. Output will be changed continuously if press and hold the button.



(4) Fix (save) an adjustment

- Press and hold [S] button for 3 seconds or more.



(5) Stop adjustment procedure halfway

- Press and hold all [+20], [S] & [-/4] buttons for 3 seconds or more.

If the button is not pressed for more than 5 minutes during setting operation, the operation will be ended.



2)-2 To fine-tune the output around 20mA

(1) Start SPAN adjustment

- Press and hold [-/20] button for 3 seconds or more.



(2) Decrease output current at 20mA

- Press [-/4] button ----- Output will be decreased gradually by pressing the button. Output will be changed continuously if press and hold the button.



(3) Increase output current at 20mA

- Press [-/20] button ----- Output will be decreased gradually by pressing the button. Output will be changed continuously if press and hold the button.



(4) Fix (save) an adjustment

- Press and hold [S] button for 3 seconds or more.



(5) Stop adjustment procedure halfway

- Press and hold all [+20], [S] & [-/4] buttons for 3 seconds or more.

If the button is not pressed for more than 5 minutes during setting operation, the operation will be ended.



3) Output increase direction Setting function

3)-1 To increase output value CW direction

(1) Start setting CW direction

- Press and hold [+ /20] and [S] buttons for 3 seconds or more.

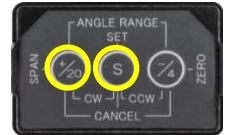

(2) Output increase direction set to CW

- Press [- /20] button ----- Output direction changed to CW increasing.

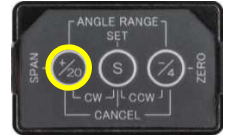

(3) Fix (save) the setting

- Press and hold [S] button for 3 seconds or more.



(4) Stop setting procedure halfway

- Press and hold all [+ /20], [S] & [- /4] buttons for 3 seconds or more.

If the button is not pressed for more than 5 minutes during setting operation, the operation will be ended.



3)-2 To increase output value CCW direction

(1) Start setting CCW direction

- Press and hold [+ /4] and [S] buttons for 3 seconds or more.



(2) Output increase direction set to CCW

- Press [- /4] button ----- Output direction changed to CCW increasing.



(3) Fix (save) the setting

- Press and hold [S] button for 3 seconds or more.



(4) Stop setting procedure halfway

- Press and hold all [+ /20], [S] & [- /4] buttons for 3 seconds or more.

If the button is not pressed for more than 5 minutes during setting operation, the operation will be ended.



4) Reset function

4)-1 Return to the prior setting

(1) Start reset mode

- Press and hold [+ / 4], [S] & [+ / 20] buttons without supplying voltage and then supply voltage and hold buttons for 3 seconds or more and release.



(2) Return to prior setting

- Press and hold [- / 4] button for 3 seconds or more.



(3) Fix (save) the setting

- Press and hold [S] button for 3 seconds or more.



(4) Stop setting procedure halfway

- Press and hold all [+ / 20], [S] & [- / 4] buttons for 3 seconds or more.

If the button is not pressed for more than 5 minutes during setting operation, the operation will be ended.



4)-2 Initialized to factory setting

(1) Start to RESET mode

- Press and hold [+ / 4], [S] & [+ / 20] buttons without supplying voltage and then supply voltage and hold buttons for 3 seconds or more and release.



(2) Return to factory setting (Initialized)

- Press and hold [- / 20] button for 3 seconds or more.



(3) Fix (save) the setting

- Press and hold [S] button for 3 seconds or more.



(4) Stop setting procedure halfway

- Press and hold all [+ / 20], [S] & [- / 4] buttons for 3 seconds or more.

If the button is not pressed for more than 5 minutes during setting operation, the operation will be ended.

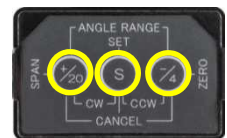

◆ Handling Instruction

(1) Angle/Resolution/Linearity of w/ASW-unit type

If the unit is adjusted by each user, the linearity and resolution will be changed as shown in the table below.

Effective Elect. Travel	Linearity	Resolution
FS=360°	0.2%FS	12bit approx.
>FS=180°	0.3%FS	12bit approx.
>FS=90°	0.5%FS	12bit approx.
>FS=45°	0.9%FS	11bit approx.
>FS=30°	1.3%FS	10bit approx.
>FS=18°	2.1%FS	9bit approx.

(2) How to check the sensor output current when setting output range

The ASW-Unit does not have a display function of output value. Please prepare a device by yourself.

(3) Fixing Output setting

The ASW-Unit does not have a function to notify that the setting has been completed. Please refer this document and make sure to fix (save) the setting.

(4) Product warranty after output setting

MIDORI has thoroughly confirmed the effects on the linearity and performance, etc. of CP36U. However please reconfirm performance after setting before use the unit.

(5) If the sensor is seemed to be failed, please return us or your local distributor without disassemble it.



<http://www.midori.co.jp>
overseas@midori.co.jp