

MEMS Tilt Angle Sensor

THD2000Z Series



THD2000Z-Series industrial inclinometers are high performance sensors used MEMS accelerometer to determine inclination in X and Y axes with excellent precision. THD2000Z is compact size and it has high vibration resistance.

- Dual Axis Measurement : Up to $\pm 60^\circ$
- High accuracy : Absolute Linearity $< \pm 1\%FS$
Stable Temperature Characteristics
- High Vibration Resistance : THD2000Z has no mechanical resonance point in the detecting element.
It is less subject to vibration.
- User-friendly Functions : Resetting Index Point,
Choice of Digital Damping Control Function

【Choice of Digital Damping Control Function】

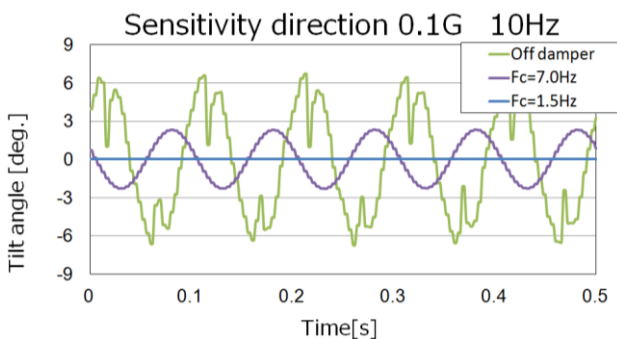

THD2000Z series implements the digital filter that would remove external noise to give the user a choice of certain filter factor from 16 available settings.

Existing inclinometers have to be add extra electrical low-pass filter or mechanical damping structure.

THD2000Z apply digital filter. It makes wider choice of cut-off frequency and easy to design frequency response.

【Easy Resetting Function for Index Point(0°)】

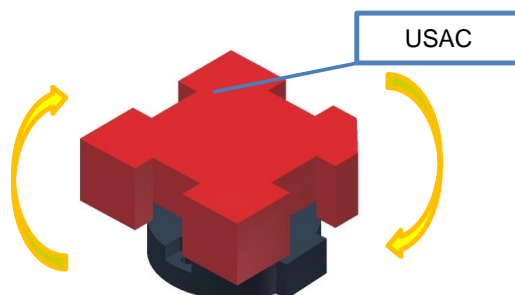

Touch USAC 5 times each 90° CCW rotatoin to THD2000Z.

Using command control by RS-485, index point (0°) can be reset ($\pm 5^\circ$ max./horizontality). Moreover using User-Settable Adjustment Card (USAC), index point (0°) can be reset without any electrical connection.

*Notes:

- USAC is optional item.
- Resetting index ponint by USAC type is option.
Please choose "THD20xxx-xxK".
- Voltage ratio output type cannot be changed by command control.

【Serial communication Function】

This series has RS485 interface model. Using RS485 serial interface command, the following functions will be able to be

1. Retrieving of electrical angle position.
2. Retrieving of Serial number.
3. Teach-in setting of index (0°) point. (Option)
4. Changing baud rate. (Option)
5. Changing output cycle of serial data. (Option)

【Dimension】 [mm]

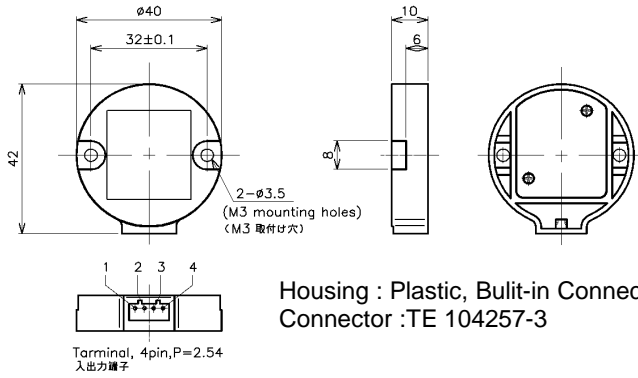

Housing : Plastic, Built-in Connector
Connector : TE 104257-3

【Tilt Angle Direction】

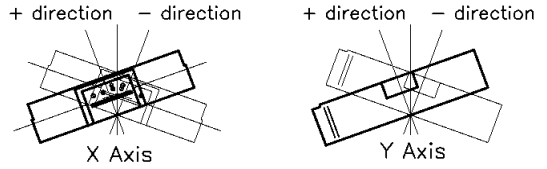

【Accessory】

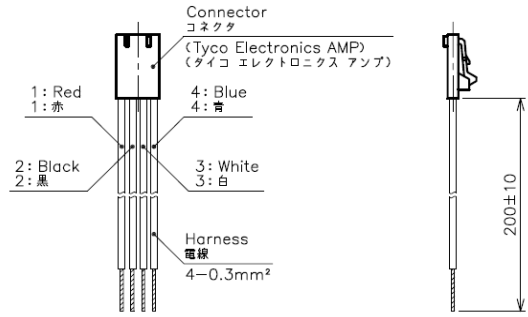

【Output Characteristics】

Voltage Ratio

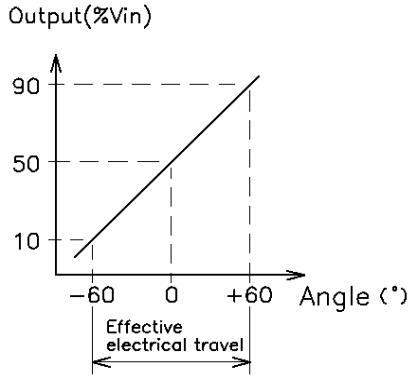

Serial RS-485

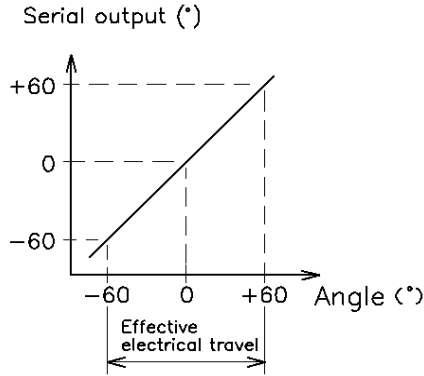

【Schematic】

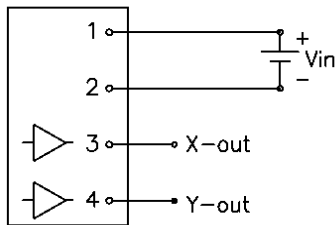

• 1,2,3,4:Terminal No.

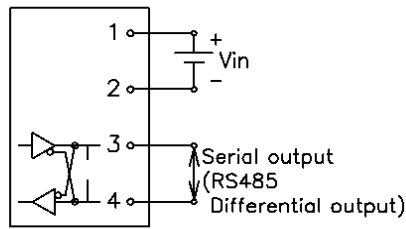

• 1,2,3,4:Terminal No.

【Specifications】

		Voltage Ratio	Serial (RS-485)
Electrial Travel		±10°, ±20°. ±30°. ±45°. ±60° Separate choice of X and Y axis (Option)	±30°, ±60°
Absolute Linearity		±1%FS	
Input Voltage		DC 5±0.25V	
Current Consumption		Steady-state: 20mA	Steady-state: 30mA
Output Range		10~90%Vin	—
Output Resolution		12bit equivalent	0.006° (Not included Noise)
Response Time		Step Response (Time Constant): 443ms (Std.) Selectable 16 steps during 70ms~900ms (Option)	
Temp. Characteristics -30~85°C (25°C std.)	0°position	±0.2°	±0.2°
	Tilt Angle	±10°: ±0.7° ±20°: ±1.2° ±30°: ±2.1° ±45°: ±3.6° ±60°: ±6.0°	±10°: 0.6° ±60°: 4.4°
EMS		IEC61000-4-3 : Level 3(10V/m)	
EMI		IEC61000-4-6 : CISPR22_A_10m	
ESD		IEC61000-4-2 : ±16kV	
Operating Temp. Range		-30~85°C	
Vibration		70m/s ² 5~500Hz (10min.) 2 hours	
Shock		1,000m/s ² , Half sine wave 6ms	
IP Grade		IP40	
Index point Resetting		Index point (±5°max/ horizontality) resetting. (Option)	

【Temperature Characteristics】

By our unique technology, THD2000Z series is individually compensated temperature characteristics each unit. THD2000Zseries realized stable temperature characteristics.

【THD2000Z Series Model Number Designation】

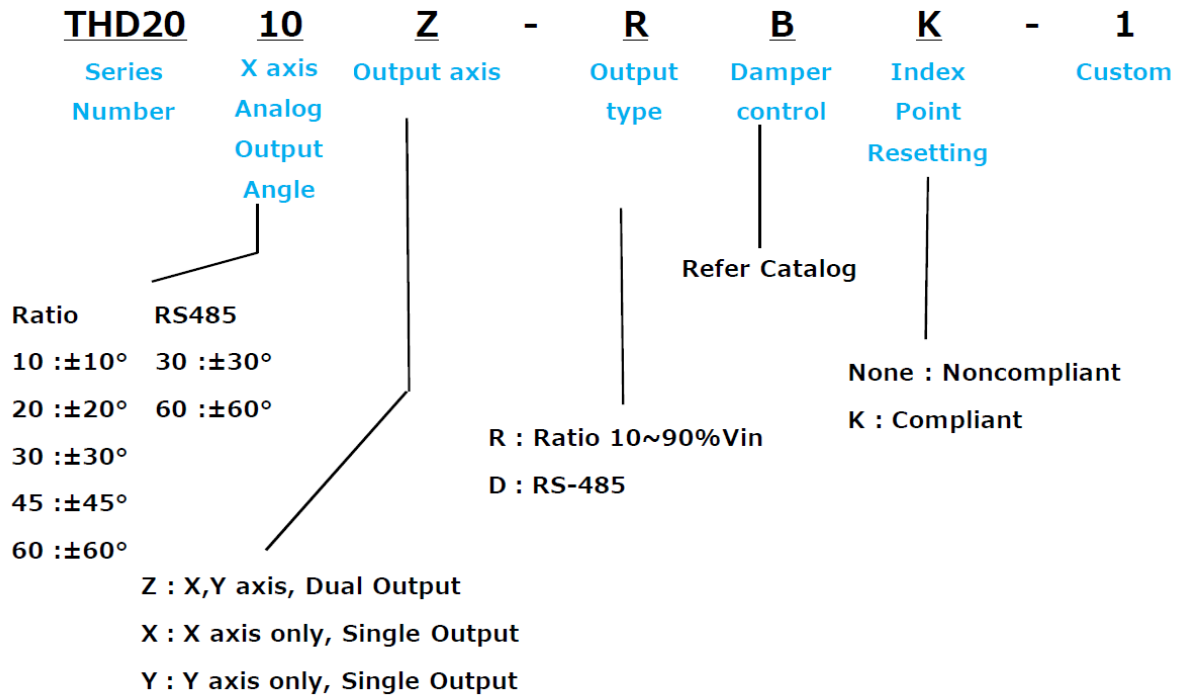

Cut-off frequency and Time constant against Damper time constant are shown the below table.
It is possible to choose the best Damper time constant by operating speed and vibration condition.

Part No.	Level	Cut-off frequency	Time constant
D0	0	11.2Hz	150ms
D1	1	9.27Hz	170ms
D2	2	7.65Hz	180ms
D3	3	6.32Hz	190ms
D4	4	5.21Hz	200ms
D5	5	4.30Hz	240ms
D6	6	3.55Hz	250ms
D7	7	2.93Hz	290ms
D8	8	2.42Hz	330ms
D9	9	2.00Hz	360ms
DA	10	1.65Hz	420ms
DB	11	1.36Hz	500ms(Standard)
DC	12	1.21Hz	590ms
DD	13	0.92Hz	700ms
DE	14	0.76Hz	840ms
DF	15	0.62Hz	990ms

【Handling Instruction】

- Hall-IC sensor is impossible to measure resistance value as a variable resistor.
- Use this sensor in the place where is protected from ESD.
- Under vibration condition, angle may not measured accurately.
- In certain temperature environment, output at 0° may be shifted by aging effect.