



MIDORI PRECISIONS CO.,LTD.

3-2-8, Shinmeidai, Hamura-shi, Tokyo 205-0023, JAPAN

Process Change Notification

Model change of LP-50F series

September 30, 2014

We introduce that LP-50F series will change Housing and Element from December 2014 production.

The changes are;

1. Housing material will be changed to Aluminum die casting and its surface anodized. (Color: Black)
2. Improvement in reliability of shaft play by changing slider and wiper design.
3. Collector part will be placed to element side. Then terminal pin will be changed.
4. Electrical and Mechanical specifications will not be changed.
5. Mounting positions will not be changed.
6. Resistance value : 500ohm will be discontinued. 10kohm will be added.
7. Shaft starting friction force will be changed. (ex. LP-50FB: from 0.4N approx. to 0.8N approx.)

Please refer Annex. 1 and 2 as well.

Best regards

A handwritten signature in black ink, appearing to read "Maki Inoue". The signature is fluid and cursive, with a long horizontal stroke extending to the right.

Maki Inoue

MIDORI PRECISIONS CO.,LTD.

Annex. 1 LP-50F

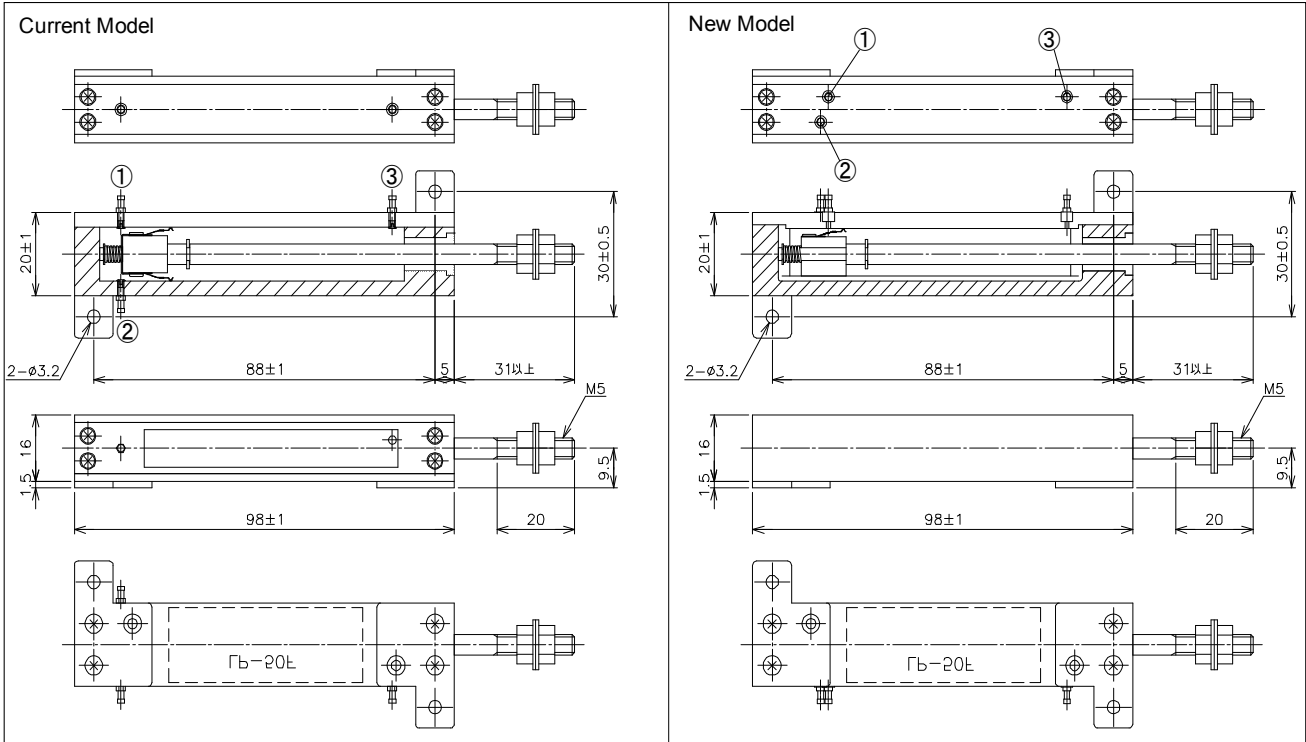
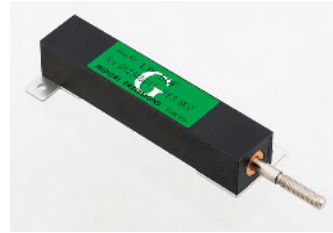

Annex. 2 LP-50FB

