

CP-xK Series - CP-3HK-100



- Contactless Hall-IC Angle Sensor
- Effective Electrical Travel : $\pm 180^\circ$
- Absolute Linearity : $\pm 0.4\%FS$ (Independent Linearity $\pm 0.2\%$)

【Material】

- Housing : Aluminum
- Shaft : Stainless Steel
- Ball Bearing : Stainless Steel
- Cover : Steel, Nickel Plate

Dimension [mm]

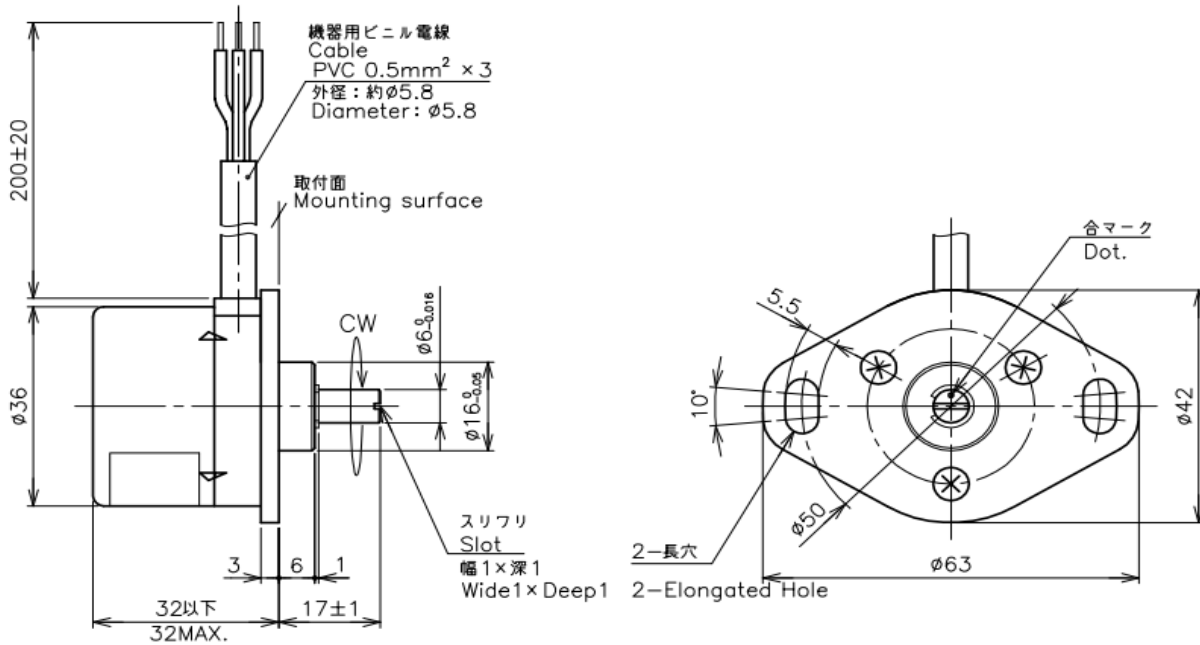

Output Characteristic

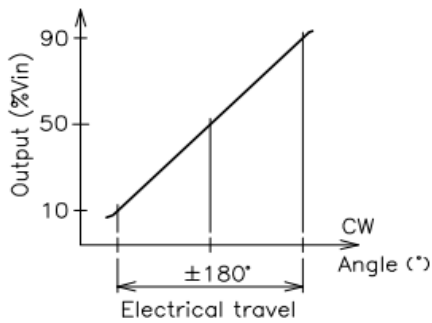

Schematic

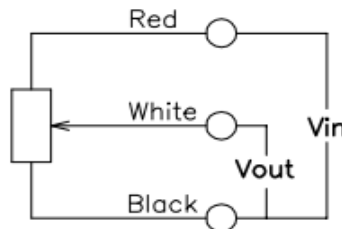

- Red, White, Black indicate harness colors.

Mounting

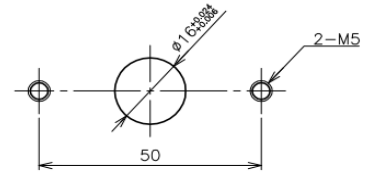

【Model No.】	CP-3HK-100
--------------------	-------------------

【Electrical Specifications】		
Effective Electrical Travel	360	°
Output Range	5 ~ 95	%Vin
Absolute Linearity	±0.4 (FS=360°) (Independent Linearity : ±0.2%FS)	%FS
Input Voltage	DC5±0.5	V
Load Resistance	MIN. 1	MΩ
Supply Current	MAX. 30	mA
Output Resolution	MAX. 0.1 (MAX. 400rpm)	°
Hysteresis	±0.5 (±0.14%FS=360°)	°
Temp. Characteristics -40 ~ +100°C (Reference Temp. 25°C)	±0.3%FS (±1.08°) FS=360°	

【Mechanical Specifications】		
Total Mechanical Travel	360 Endless	°
Torque	MAX. 2	mN·m
Thrust Load Tolerance	4	N
Radial Load Tolerance	14	N
Mass	Approx. 80	g

【Environmental Specifications】		
Life Cycles	MIN. 50 Million	Cycle
Category Temperature Range	-40 ~ +100	°C
Storage Temperature Range	-40 ~ +100	°C
Vibration	100m/s ² 5 - 500Hz(6 min.) 3 axis 2 hours	
Shock	1000m/s ² 11ms 6 directions 3 times	
ESD (Case to Each Terminal)	±8kV (IEC61000-4-2)	
ESD (Between Each Terminal)	±8kV (IEC61000-4-2)	
IP Rating	IP54 (Except shaft side from mounting surface)	

■ Handling Instructor

- In applying input power, voltage Vin must rise to 4.5V within 0.2 second, otherwise, output shall be disabled (Vout=0V)
- These products do not shielded with shaft bearing.
- Do not use Hall-IC sensor as a variable resistor.
- This product may be influenced from external magnetic field.
- Use this sensor in the place where is protected from ESD.
- This model is available to remove mounting flange.