

Technical Data

Blue Pot :

Magneto-Resistive Element type contactless position sensor

Blue Pot is the general term that Midori has used for the MR (Magneto Resistive) element contactless potentiometer. Blue Pot is identified by blue-colored name plate attached to the part.

Magneto resistive element has 3 terminals. Its midpoint potential is varied by migration of the magnetic field. Voltage is supplied to each end terminals of the MR-element, then the output is created from the terminal at the middle.

Compared to typical contact potentiometer, Blue Pot is electrically noiseless, offers high resolution, high response time, and long life.

Features

1. Electrically Noiseless

There is no electrical noise in the output regardless of the displacement velocity.

2. Resolution

Output resolution is practically infinite.

3. Output Smoothness

Compared to contact potentiometer such as wire wound and conductive plastic potentiometer, since there is no sliding electrical noise due to the contactless design, the output smoothness of Blue Pot is much superior to that of contact potentiometer.

4. Low Torque, Low Friction

Shaft torque and friction are very small due to the contactless design.

5. High Frequency Characteristic

In theory, magneto resistive frequency-independence effect is up to 10GHz.

6. Rapidity

Superior to rapid response (except built in AMP circuit type).

7. Low Current Consumption

The combination of magnet and semiconductor seldomly has any needs for electromagnetic energy such as light source being needed in optical sensor (except built in AMP circuit type).

8. Long life

There is no mechanical friction between the parts except at the shaft bearing. Blue Pot has superb long life.

Technical Data

Magnet Resistive Element for Angle Sensor :

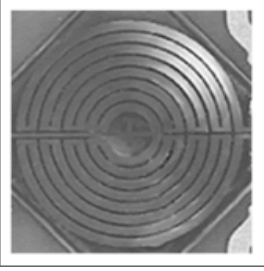

Principle

1. Sensing Method

Blue Pot consists of the combination of magneto resistive element and magnet. There are following sensing methods:

- (1) Create output voltage change by planarly moving the magnet near the magneto resistive element.
- (2) Create output voltage change by moving the magnet resistive element near the magnet.
- (3) Fix the magneto resistive element and magnet close together, and move a magnetic material yoke to create output voltage change.

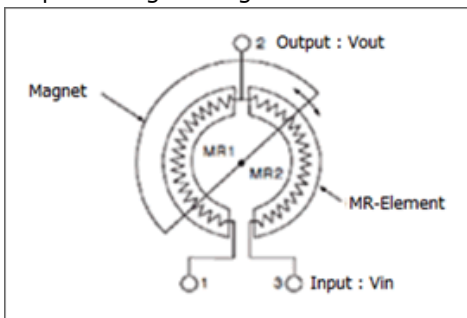

2. Relations between displacement and output

When supplying input voltage V_{in} to terminal 1 and 3, and then by displacing the position of magnet on the shaft, relations between output voltage V_{out} from terminal 1 and 2 and V_{in} are as follows:

- (1) When magnet is at the side of MR2, resistance value of magneto resistive element is $MR1 < MR2$. Output voltage is $V_{out} < 1/2V_{in}$
- (2) When magnet is at middle between MR1 and MR2, resistance value of magneto resistive element is $MR1 = MR2$. Output voltage is $V_{out} = 1/2V_{in}$
- (3) When magnet is at the side of MR1, resistance value of magneto resistive element is $MR1 > MR2$. Output voltage is $V_{out} > 1/2V_{in}$

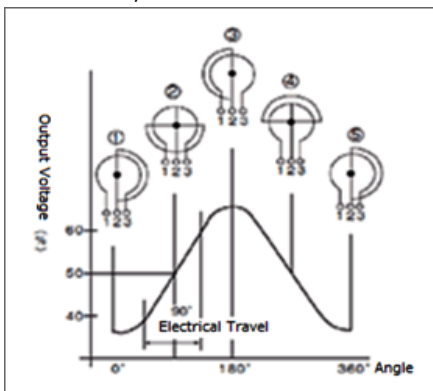

Technical Data

Signal Converting Method

Blue Pot uses many different converting methods.
The following is a typical converting method of Blue Pot.

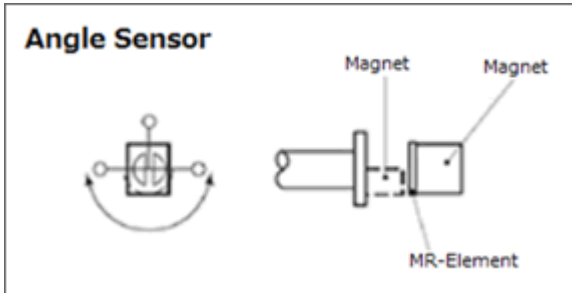

Temperature Characteristics

Blue Pot has superb temperature characteristics compared to contact potentiometer.
Magneto resistive element for Blue Pot products has resistance temperature characteristics as shown on chart 3.

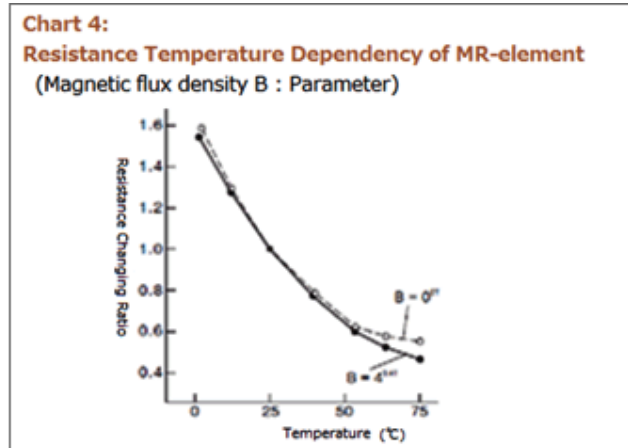
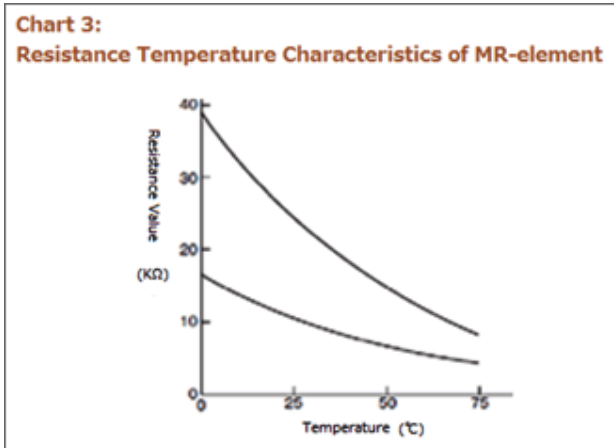

Also as shown chart 4, temperature characteristics depend on the amount of density of the magnetic flux.
Temperature characteristics of MR1 and MR2 at the second quadrant of magneto resistive elements are different from individuals caused by manufacturing variations.

Since magneto resistive effect with temperature is not a uniform state, output voltage of Blue Pot fluctuates as shown on chart 5 with changing temperature.

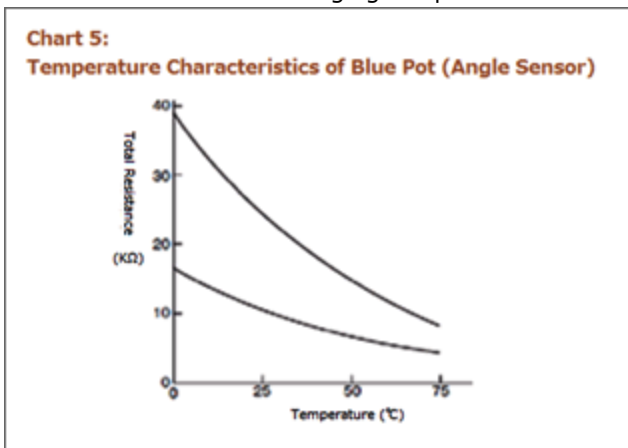

Technical Data

Temperature Compensation

As shown chart 6-1, temperature characteristics at the middle angle position are improved in the range from low to high temperature using series-parallel resistance.

As showing chart 6-2, by also using thermistor, it is feasible to improve temperature characteristics of the whole electrical angle.

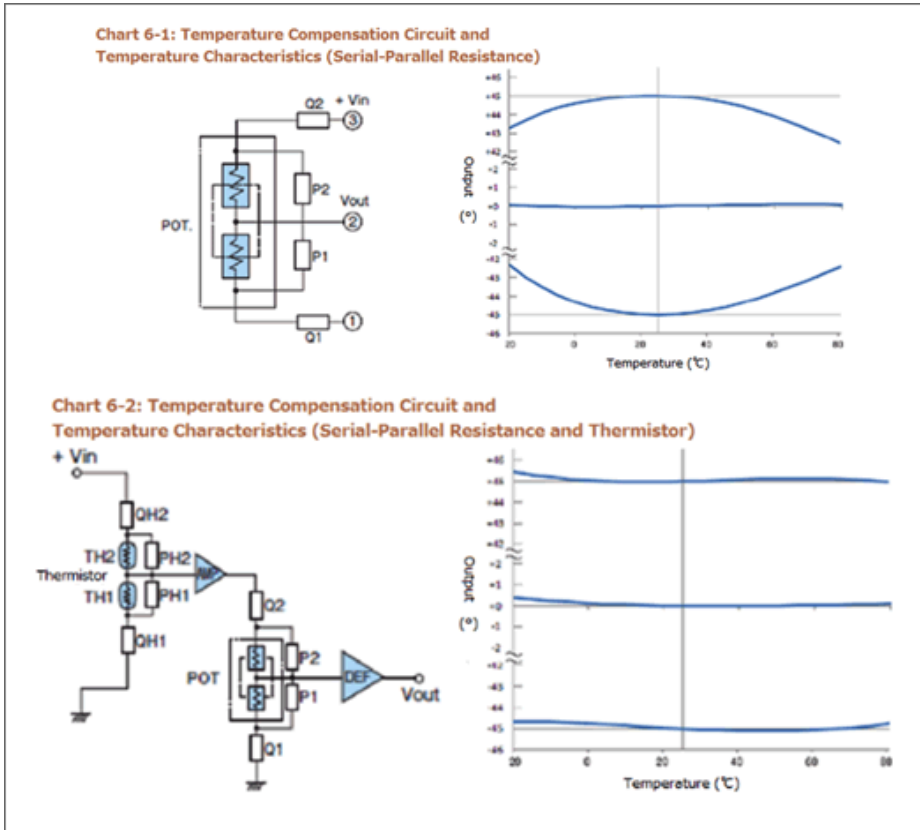

Technical Data

Mounting Instruction

Mounting Method

(1) Bushing Mount (Mounting Method A)

- Insert threaded part of pot through from the back side of mounting board and fasten the pot by a nut with washer.
- Be sure to place a washer behind of the nut.
- As for the pot with a stopper pin, make a hole for a stopper pin on a mounting board.
- Do not rotate the pot itself when tightening the nut. This may cause malfunction of the sensor.
- Do not over tighten the nut. This may damage the threaded part of the pot.
- In case of installing the pot at places where there is a lot of vibration, the mounting screws can be locked by adhesive.

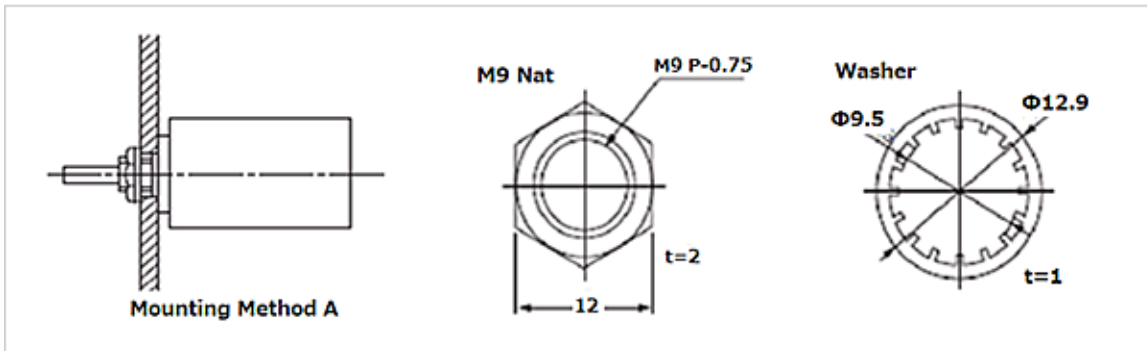

(2) Screw Mount (Mounting Method B1 and B2)

- Fasten the pot with screws into the tapped holes which is on the mounting surface of the Pot.
- Please use certain length of screw.
- In case of selecting mounting method 'B1', create a shaft hole on the mounting board which diameter is larger than the pot shaft diameter.

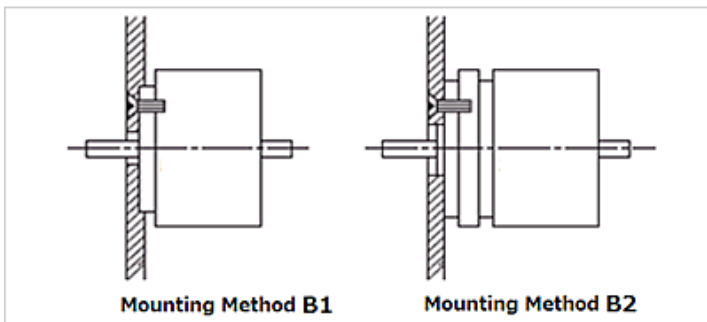

Technical Data

Amplifier for Blue Pot

1. Input Voltage

Apply voltage to terminal 1 to 3 must be lower than specified voltage. Otherwise the magneto resistive element will generate heat at the higher voltage and this will cause output deviation.

2. Input Impedance of AMP

Added input impedance of AMP should be more than 500 times the impedance of Blue Pot.

If the input impedance is lower, it will cause a decrease in temperature characteristics of Blue Pot.

3. Exogenous Noise

Reducing the distance between blue pot and AMP shall lessen the effect of exogenous noise. In case of increasing exogenous noise, connect Blue Pot and AMP by twisted pair wire or shielded wire or add low-pass filter in front of AMP.

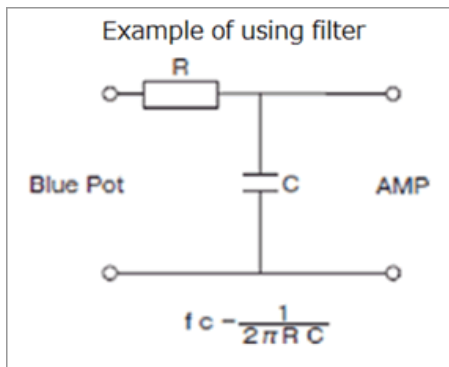

Handling Instruction

Potentiometers are precisely assembled and adjusted. Please handle them carefully as a precision device.

1.

- Do not disassembling the pot.
- Do not modify the Pot

(May effect the precision and cause malfunction.)

2.

- Do not drop the Pot.
- Do not strike one part against another

(May damage the terminals or cause wires to disconnect.)

3.

- Do not apply excessive voltage or current.
- (May damage resistive element an electronic Components.)

- make sure to use digital tester.

(may damage resistive element and electronic components if analog tester is used.)

Technical Data

4.

- Mount without tapping or squeezing into a panel.
- Use suitable tools
(May break or cause failure.)

5.

- Use wire that has sufficient length for connection terminals.
- Use wire less than 0.3mm² (AWG22) in cross section.
(Insufficient length of wire or use of larger wire may cause damage to the terminals or disconnection inside the pot.)

6.

- Be sure to connect appropriately.
- Do not apply voltage on output terminals.
(May damage resistive element and electronic components.)

7.

- Solder no more than 5 seconds at 300°C MAX.
(High temperature may damage inside of pot.)

8.

- Do not apply excessive torque to the mechanical stopper of rotary type pot.
(may cause breakage of stopper. Stopper strength: 0.3-0.5N.m MAX. typical)

9.

- Do not immerse in water or pour water or chemicals on the pot.
(may cause output failure)

10.

- Observe precautions for handling electrostatic discharge sensitive devices.
(Orange Pot is using the electrostatic discharge sensitive semiconductor circuits.)

11.

Do not store pot in the following conditions.

- High humidity
- Dusty environment
- Place where salinity or corrosive gases are present.
- Vibrating place

Units

The units in the web site is the International System of Units (SI).

Torque	1kgf·m = 9.80655N·m, 1N·m = 0.10197kgf·m = 101.97gf·m
Force	1kgf = 9.80655N, 100gf = 980.655mN, 1N = 0.10197kgf = 101.97gf, 5N = approx.500gf
Acceleration	1G = 9.80655m/s ² , 150m/s ² = approx. 15G, 500m/s ² = approx. 51G
Magnetic Flux Density	1G = 1x10 ⁻⁴ T

Technical Data

In addition to the Handling Instructions in this web site, please read the following guidelines with a good understanding of its contents:

- Manufacturing date indication (JEITA RC-0901)
- Precautions of potentiometer (JEITA RCR-2191A)
- Safety Application Guide on Components for Electric Devices and Electric Manufactures (JEITA RCR-1001B)

Guaranty

1. If our products are intended to be used for any applications that required high reliability such as nuclear power, satellite, and medical devices, please contact us before purchasing.
2. Environmental specifications that are indicated on this web catalog are guaranteed based on the test conditions established by our company. It is not guaranteed the performance in actual use. When making a decision to adopt our products, please be sure to examine the products by mounting and testing them beforehand at your own risk.
3. Although specifications and handling instructions of each products were offered in this web catalog, the function may be limited depending on the handling conditions. When making a decision to adopt our products, please obtain detailed documentations of the products from us.
4. As a principle, we cannot provide compensation for any damages to the customer's equipment or device caused by the breakdown or malfunction of our products.
5. Our products are electronics components. Repair or replacement is not supported except some of the products.
6. We do not accept any returns or exchanges for the product. Please carefully check the specifications of the product before placing an order.
7. The content of this website is subject to change without notice for the sake of improvement.
8. Please contact the sales department if you have any questions or concerns.

About This Web Catalog

The information in this web catalog is subject to change without prior notice.