

# Technical Data

## Green Pot : Conductive Plastic Potentiometer

Green Pot is the general term that Midori has used for conductive plastic contact potentiometer.

Green Pot is identified by Green-colored name plate attached to the part.

Conductive plastic element is the unibody element in which a purified carbonaceous filler was brought to the surface of the plastic resin as a thick film resistor using heat. There are two different types of element: Co-mold element type in which the resistive element has an extreme mirror surface sliding face, and the less expensive Screen element type in which the carbon film is printed on a plastic base to create the resistive element.

### Features

---

#### 1. Co-mold Element

Forming base materials, resistive element, and corrector spring are formed together. There is mechanical stability and durability against vibration and shock compared to wire wound potentiometer.

#### 2. Screen Element

Screen element delivers equal performance to that of Co-mold Element and moreover also provides superior cost-effectiveness.

#### 3. Resolution

Output resolution is practically infinite.

#### 4. Long Life

Conductive plastic element has smooth surface. Therefore, there is less wear between the element surface and the wiper contact point.

#### 5. Temperature Effect

Resistive temperature characteristic of conductive plastics is higher than that of wire wound potentiometer. There are two types:  $\pm 400\text{ppm/K}$  and  $\pm 1000\text{ppm/K}$ .

Therefore, in case of using the Green Pot as a variable resistor, effect of temperature is direct but in case of using Green Pot as potentiometer, the effect of temperature is small.

#### 6. High Frequency Characteristic

Integral molded resistive element for Green Pot has lower inductance compared to that of wire wound and is able to create stable output under the frequency of 100kHz MAX.

#### 7. Low Outgas Generation

In the high vacuum like in space, plastic produces gas and it has a potentially detrimental effect on electric devices.

Conductive plastic element of Green Pot produces less gas in the high vacuum, therefore it has been used in satellite application.

#### 8. Fast Response

Since Green Pot adopted extreme mirror surface resistive element and multi-contact wiper, it is capable to measure at up to 3m/s shaft rotational speed in a single rotation. In continuous rotation, it is capable to measure at up to 1m/s shaft rotational speed.

(Take model CPP-45 for example, it is capable to read out at rotations at up to 2000rpm within a single rotation and up to 600rpm in continuous use)

# Technical Data

## Principle

### Sliding Method

Sliding method is different slightly for each model but Green Pot has mainly adopted the following methods:

#### 1. Angle Sensor

Resistive Part: Noble metal alloy multi-contact wiper

Collector Part: Combination of a noble metal alloy spring ring and a collector spring

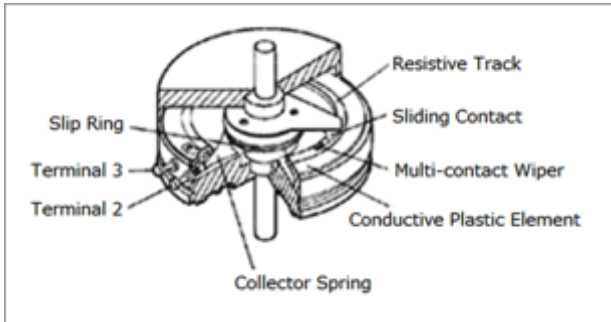

#### 2. Linear Sensor

Resistive Part: Noble metal alloy multi-contact wiper

Collector Part: Combination of collector track and multi-contact wiper

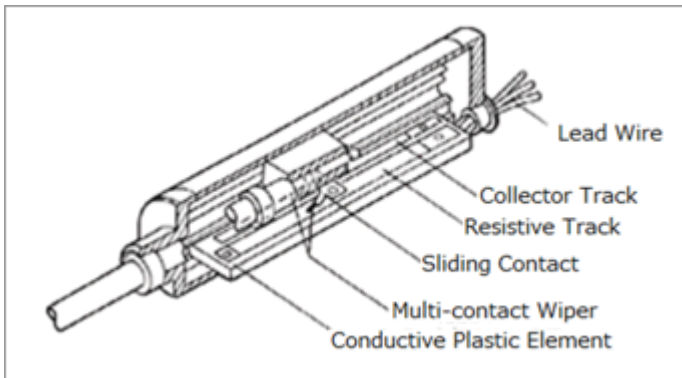

# Technical Data

## Mounting Instruction

### Mounting Method

#### (1) Bushing Mount (Mounting Method A)

- Insert threaded part of pot through from the back side of mounting board and fasten the pot by a nut with washer.
- Be sure to place a washer behind of the nut.
- As for the pot with a stopper pin, make a hole for a stopper pin on a mounting board.
- Do not rotate the pot itself when tightening the nut. This may cause malfunction of the sensor.
- Do not over tighten the nut. This may damage the threaded part of the pot.

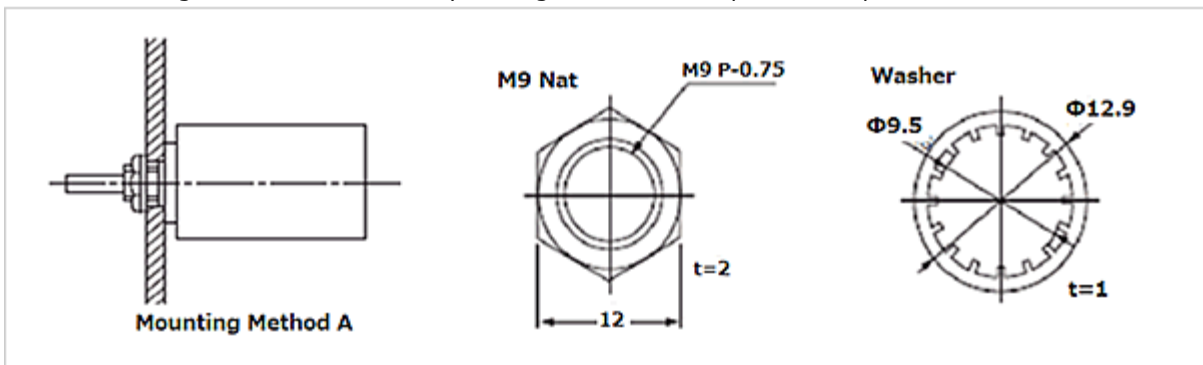

#### (2) Screw Mount (Mounting Method B1 and B2)

- Fasten the pot with screws into the tapped holes which is on the mounting surface of the Pot.
- Please use certain length of screw.
- In case of selecting mounting method 'B1', create a shaft hole on the mounting board which diameter is larger than the pot shaft diameter.

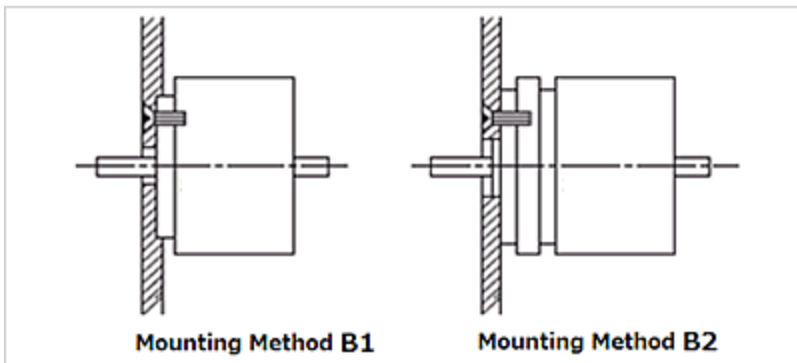

# Technical Data

## (3) Servo Mount (Mounting Method C1 and C2)

- Install a pot on the mounting board using mounting cleats .
- Make hole to fit diameter of matching flange.
- Do not tighten the screws for the mounting cleats until pot body is fixed at the desired position.
- Gears or couplings on the shaft smaller than diameter of mounting hole may be more convenient for installation.
- In case of using mounting method 'C1', place a few mounting cleats equally spaced by mounting hole.
- If there is no space to place the mounting cleats, it is recommended to use mounting method 'C2'.

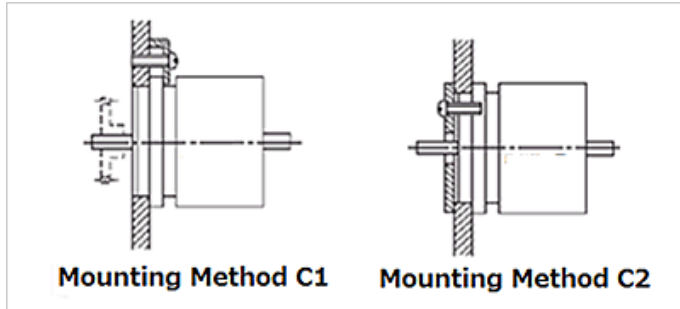

① CP-2F	
② Abolishment	
③ CPP-35 CPP-35B	
④ CP-45H CPP-45 CPP-45B CPP-5S	
⑤ CPP-60	

# Technical Data

## Effects of Loading

If finite load resistance is loaded on sensor output, linearity will become distorted as expressed in the following equation.

$$E_{\max} = \frac{14.8}{\frac{RL}{RP} + 0.22} (\%)$$

$E_{\max}$  : Maximum linearity distortion caused by load resistance

RP : Total Resistance of Potentiometer

RL : Load Resistance

Show above equation in a graphic form, as shown right:

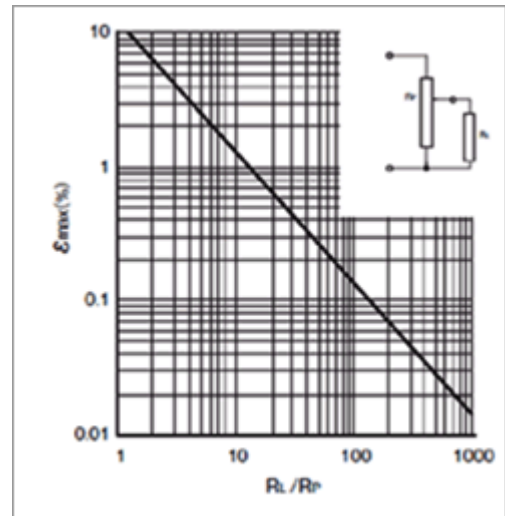

JEITA (Japan Electronics and Information Technology Industries Association) recommends that the added load resistance should be more than 100 times of the total resistance.

The higher the load resistance, the less effect of electrical noise on the output of the potentiometer. It is also effective in increasing the durability of the Green Pot.

## Equivalence Noise Resistance and Load Resistance

Contact potentiometer generates the equivalence noise resistance because of its structure. It is possible to reduce the effect of noise resistance on the output by adding large load resistance to the potentiometer.

The equivalence noise resistance is expressed "Re" as shown the right figure.

Voltage at point A is divided as shown the formula below.

$$V_a = \frac{RL}{(Re + RL)} \times V_{out}$$

Va: Voltage at point A

Vout: Output voltage of Potentiometer

RL: Load Resistance

Re: Equivalence Noise Resistance

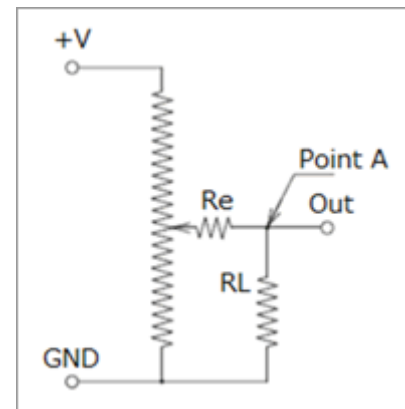

For example, if +V= 10V, Re= 100Ω, and RL= 10KΩ, output of each angle is as shown below:

Pot Postion / Va (V)	Ratio Conversion (%)	Error (%)
at 10% / 0.99	9.90	-0.10
at 30% / 2.97	29.70	-0.30
at 50% / 4.95	49.50	-0.50
at 70% / 6.93	69.31	-0.69
at 90% / 8.91	89.11	-0.89

But if RL= 100KΩ then the error becomes smaller as shown below:

Pot Postion / Va (V)	Ratio Conversion (%)	Error (%)
at 10% / 1.00	9.99	-0.01
at 30% / 3.00	29.97	-0.03
at 50% / 5.00	49.95	-0.05
at 70% / 6.99	69.93	-0.07
at 90% / 8.99	89.91	-0.09

# Technical Data

## Reducing Power

It is necessary to decrease the rated dissipation by the condition of the (1) Operating Temperature, (2) Load Resistance, (3) (4) Specifications to avoid damaging resistive element.

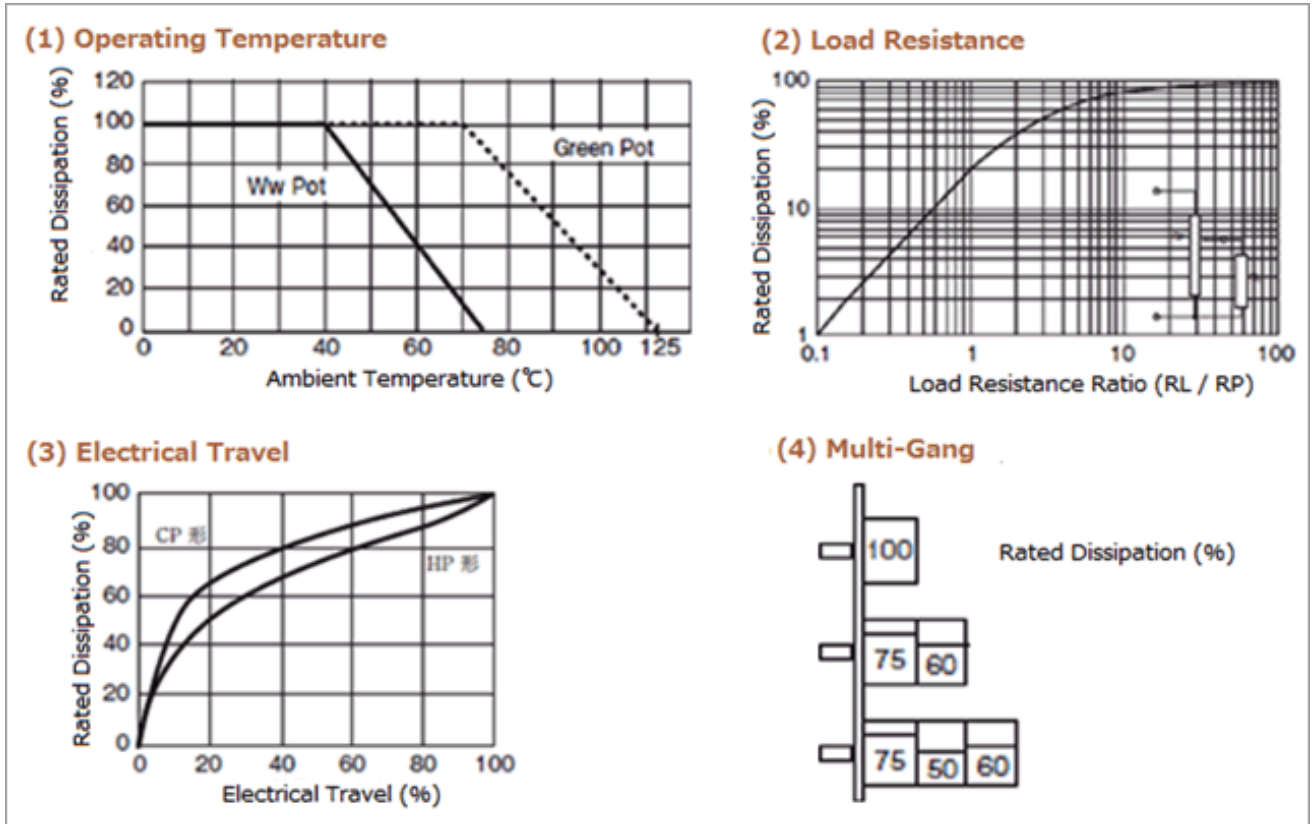

## Input Voltage

Maximum input voltage (V) defined by the rated dissipation can be calculated by using the following formula.

$$V = \sqrt{W \times R}$$

V: Maximum Input Voltage

R: Total Resistance - Total Resistance Tolerance

W: Rated Dissipation

## Shorted Segment

It is an area of the resistive element where the area has fixed output voltage ratio. The area is not included in the total effective electrical travel.

## Technical Data

### The Difference between Shorted Segment and Extra Segment

Depending on the process of resistive element, extra segments might be added outside of the total electrical angle. Voltage output characteristics of short segment and extra segment are both the same but in reading resistance value, there is difference as shown in the below charts. In extra segment, it is necessary to place terminals at the designated angle.

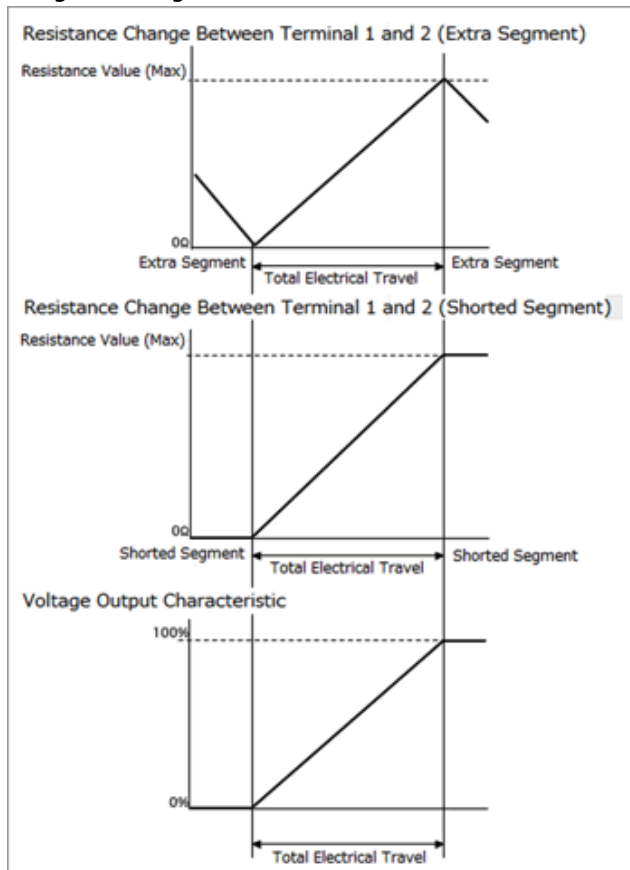

# Technical Data

## Center Tap

Green Pot also offers the option for center tap (C.T) to be added like Wire Wound Pot. Unlike Wire Wound Pot, it is not easy to install the center tap at any position.

Conductive plastic resistive element is molded or should be printed the resistive track, the terminals, and the taps together. It is necessary to perform separate specific process even just for adding one piece of center tap.

Normally, there is shorted segment around a tap position (B-Tap). To change the process of tap addition, it is available to remove most all of the shorted segment (A-Tap). However, as for A-Tap, it has the characteristics of a slightly higher resistance value than typical pot. We will select B-Tap if tap condition is not specified.

## Tap Condition

C.T (A) : There is a little resistance between tap and resistive element but this has little impact on output.

C.T (B) : Normally use for input. There is shorted segment approx.  $0.5^\circ - 5^\circ$  and output will be flat in the range.

## Example of Schematics and Output Characteristics of Center Tap

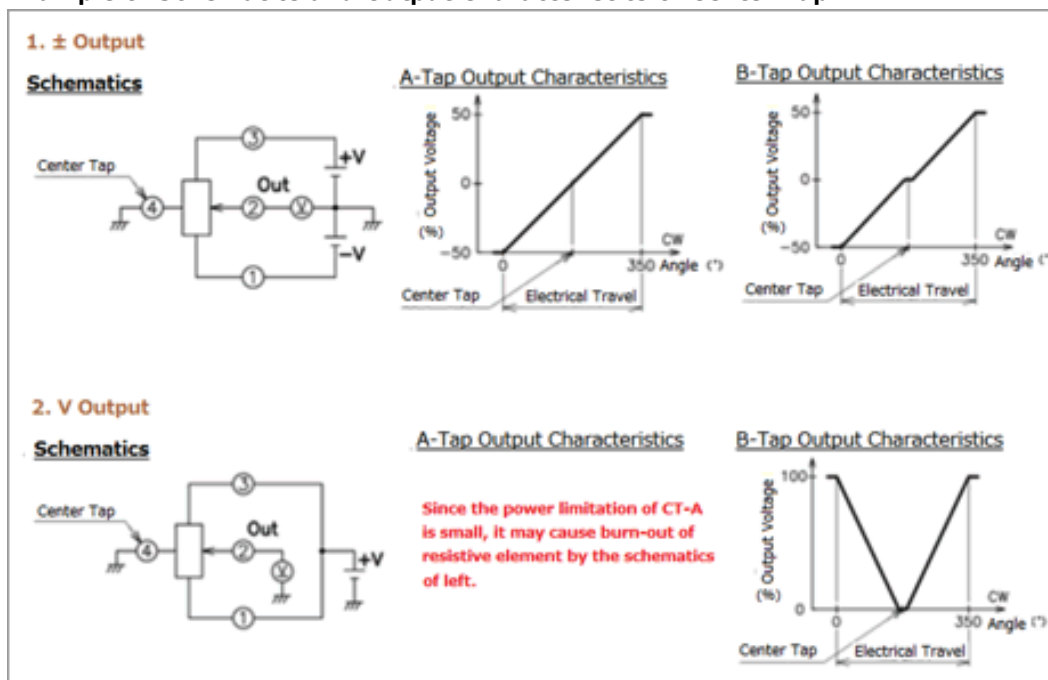

## Operating Suggestions

If Green Pot is used in an environment with vibration or dither operation, resistive element may become partially worn by a sliding wiper causing shorter lifetime of the Green Pot.

Contactless sensor such as Blue Pot and Orange Pot are more suitable for those kinds of operating environment.



# Technical Data

## Burnout of Resistive Element

### 1. Wiring

Potentiometer is used for obtaining output voltage ratio from input voltage. Therefore, apply DC voltage ( $V_{in}$ ) and read out the voltage ( $V_{out}$ ) between output terminal and GND. Do not use potentiometer as a variable resistor.

### 2. Load Resistance

We recommend to add load resistance that is more than 100 times of the total resistance value. If added load resistance is low, current flow at power-supply line (Terminal 1 to 3 or lead wire black to red) will flow to the output line (Terminal 1 to 2 or lead wire white to red) and may cause burnout of resistive element when wiper at low-value resistance position. To avoid burn-out the resistive element, set wiper current lower than 1mA.

### 3. Miswiring

If output terminal (or output lead wire) is connected to power-supply line, it will increase the chance of burning out the resistive element.

### 4. Multimeter

When checking total resistance or measuring resistance value of Green Pot by analog multimeter, increase the range of the analog multimeter to make the needle move widely and higher current flow may be generated. Please use analog multimeter with lower range than 1mA or we recommend to use the digital multimeter.

### 5. Over Rated Dissipation

If over voltage such as surge is supplied to potentiometer, it will cause burnout of the resistive element.

## Handling Instruction

---

Potentiometers are precisely assembled and adjusted. Please handle them carefully as a precision device.

### 1.

- Do not disassembling the pot.
  - Do not modify the Pot
- (May effect the precision and cause malfunction.)

### 2.

- Do not drop the Pot.
  - Do not strike one part against another
- (May damage the terminals or cause wires to disconnect.)

### 3.

- Do not apply excessive voltage or current.
- (May damage resistive element an electronic Components.)
- make sure to use digital tester.
- (may damage resistive element and electronic components if analog tester is used.)

## Technical Data

### 4.

- Mount without tapping or squeezing into a panel.
- Use suitable tools  
(May break or cause failure.)

### 5.

- Use wire that has sufficient length for connection terminals.
- Use wire less than 0.3mm<sup>2</sup> (AWG22) in cross section.  
(Insufficient length of wire or use of larger wire may cause damage to the terminals or disconnection inside the pot.)

### 6.

- Be sure to connect appropriately.
- Do not apply voltage on output terminals.  
(May damage resistive element and electronic components.)

### 7.

- Solder no more than 5 seconds at 300°C MAX.  
(High temperature may damage inside of pot.)

### 8.

- Do not apply excessive torque to the mechanical stopper of rotary type pot.  
(may cause breakage of stopper. Stopper strength: 0.3-0.5N.m MAX. typical)

### 9.

- Do not immerse in water or pour water or chemicals on the pot.  
(may cause output failure)

### 10.

- Observe precautions for handling electrostatic discharge sensitive devices.  
(Orange Pot is using the electrostatic discharge sensitive semiconductor circuits.)

### 11.

Do not store pot in the following conditions.

- High humidity
- Dusty environment
- Place where salinity or corrosive gases are present.
- Vibrating place

## Units

The units in the web site is the International System of Units (SI).

Torque	1kgf·m=9.80655N·m、1N·m=0.10197kgf·m=101.97gf·m
Force	1kgf=9.80655N、100gf=980.655mN、1N=0.10197kgf=101.97gf、5N=approx.500gf
Acceleration	1G=9.80655m/s <sup>2</sup> 、150m/s <sup>2</sup> =approx. 15G、500m/s <sup>2</sup> =approx. 51G
Magnetic Flux Density	1G=1x10 <sup>-4</sup> T

# Technical Data

In addition to the Handling Instructions in this web site, please read the following guidelines with a good understanding of its contents:

- Manufacturing date indication (JEITA RC-0901)
- Precautions of potentiometer (JEITA RCR-2191A)
- Safety Application Guide on Components for Electric Devices and Electric Manufactures (JEITA RCR-1001B)

## Guaranty

---

1. If our products are intended to be used for any applications that required high reliability such as nuclear power, satellite, and medical devices, please contact us before purchasing.
2. Environmental specifications that are indicated on this web catalog are guaranteed based on the test conditions established by our company. It is not guaranteed the performance in actual use. When making a decision to adopt our products, please be sure to examine the products by mounting and testing them beforehand at your own risk.
3. Although specifications and handling instructions of each products were offered in this web catalog, the function may be limited depending on the handling conditions. When making a decision to adopt our products, please obtain detailed documentations of the products from us.
4. As a principle, we can not provide compensation for any damages to the customer's equipment or device caused by the breakdown or malfunction of our products.
5. Our products are electronics components. Repair or replacement is not supported except some of the products.
6. We do not accept any returns or exchanges for the product. Please carefully check the specifications of the product before placing an order.
7. The content of this website is subject to change without notice for the sake of improvement.
8. Please contact the sales department if you have any questions or concerns.

## About This Web Catalog

---

The information in this web catalog is subject to change without prior notice.